

Drawing #-60228
Two Piece Monitor Arm Setup

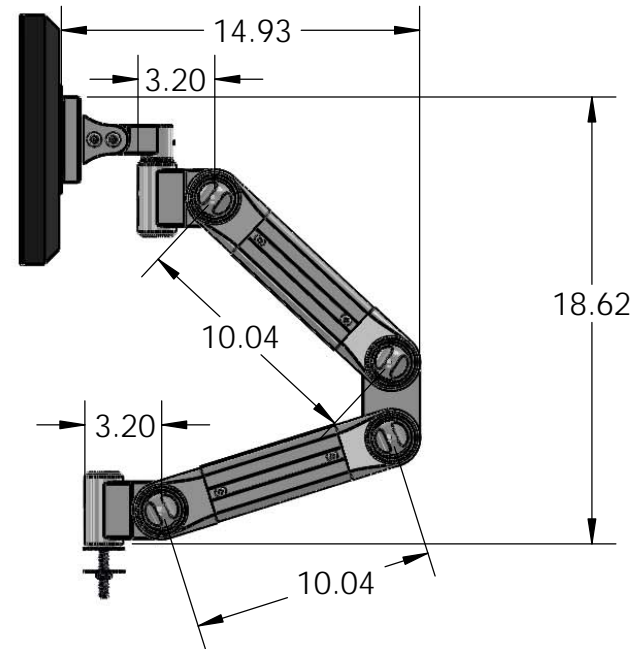

PROPRIETARY AND CONFIDENTIAL
THE INFORMATION CONTAINED IN THIS DRAWING IS THE SOLE PROPERTY OF CUSTOM PRODUCTS AND SERVICES. ANY REPRODUCTION IN PART OR AS A WHOLE WITHOUT THE WRITTEN PERMISSION OF CUSTOM PRODUCTS AND SERVICES IS PROHIBITED.

		UNLESS OTHERWISE SPECIFIED:		NAME	DATE			
		DIMENSIONS ARE IN INCHES	DRAWN	NJN	8/19/15	TITLE: "Jury Box Monitor Arm"		
		TOLERANCES:	CHECKED					
		FRACTIONAL ±	ENG APPR.					
		ANGULAR: MACH ± BEND ±	MFG APPR.					
		TWO PLACE DECIMAL ±	Q.A.			SIZE	DWG. NO.	REV
		THREE PLACE DECIMAL ±	COMMENTS:			A	60228	
		INTERPRET GEOMETRIC TOLERANCING PER:				SCALE: 1:12	WEIGHT:	SHEET 1 OF 2
		MATERIAL						
NEXT ASSY	USED ON	FINISH						
APPLICATION		DO NOT SCALE DRAWING						

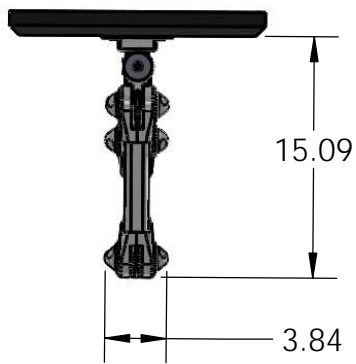
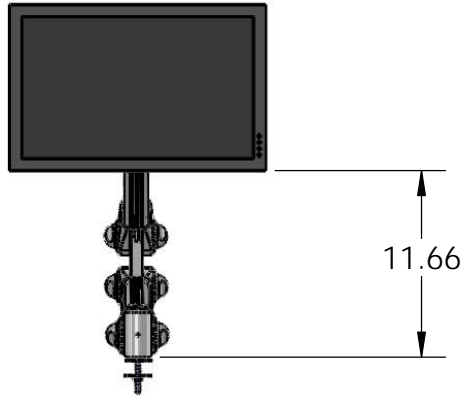
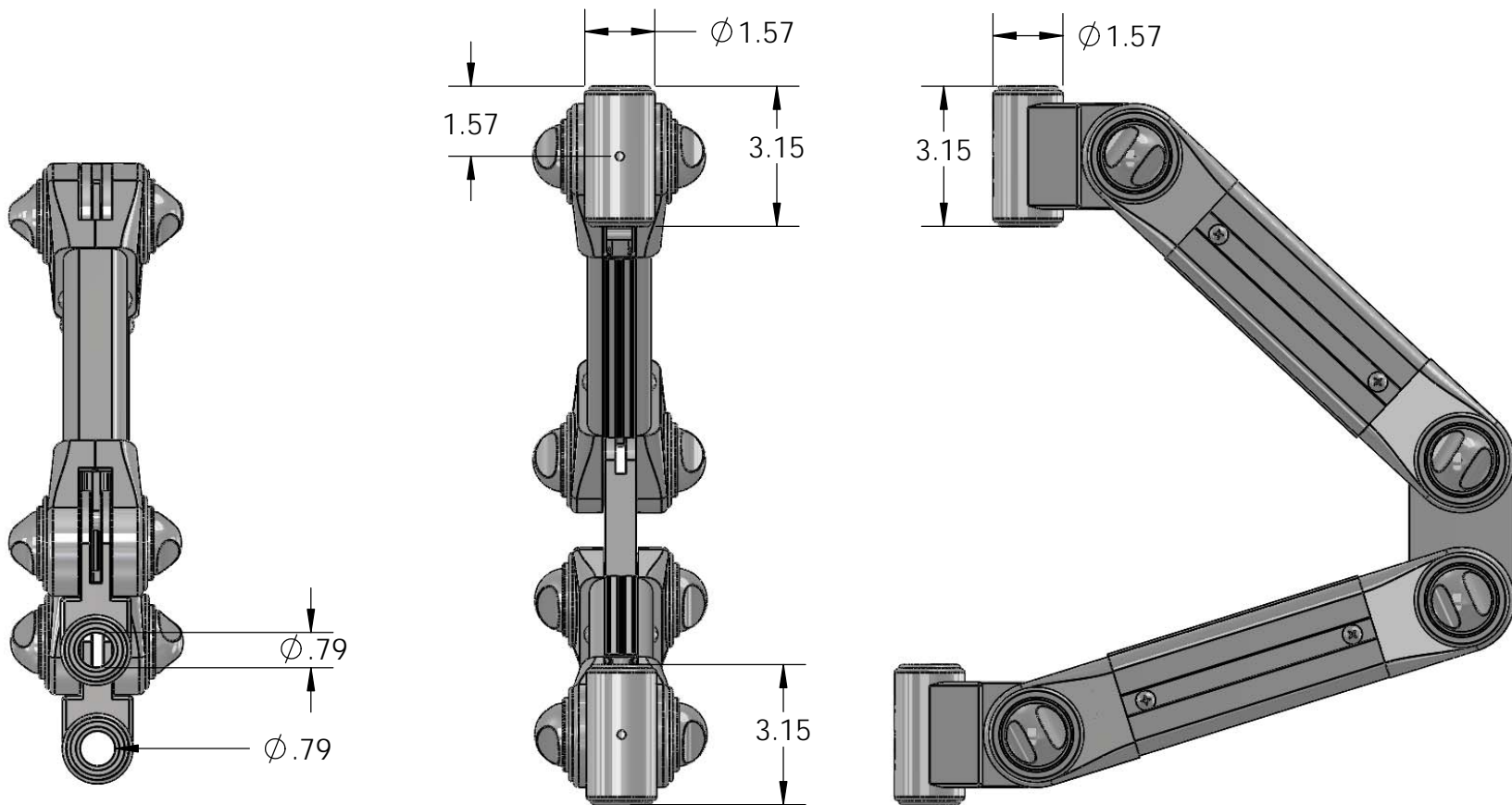

PROPRIETARY AND CONFIDENTIAL
 THE INFORMATION CONTAINED IN THIS DRAWING IS THE SOLE PROPERTY OF CUSTOM PRODUCTS AND SERVICES. ANY REPRODUCTION IN PART OR AS A WHOLE WITHOUT THE WRITTEN PERMISSION OF CUSTOM PRODUCTS AND SERVICES IS PROHIBITED.

		UNLESS OTHERWISE SPECIFIED:		NAME	DATE		
		DIMENSIONS ARE IN INCHES TOLERANCES: FRACTIONAL \pm ANGULAR: MACH \pm BEND \pm TWO PLACE DECIMAL \pm THREE PLACE DECIMAL \pm	DRAWN	NJN	8/19/15	TITLE: 60228 Arm Only	
		INTERPRET GEOMETRIC TOLERANCING PER:	CHECKED				
		MATERIAL	ENG APPR.				
NEXT ASSY	USED ON	FINISH	MFG APPR.				
APPLICATION		DO NOT SCALE DRAWING	Q.A.			SIZE	DWG. NO.
			COMMENTS:			A	60228
						SCALE: 1:12	WEIGHT:
							SHEET 2 OF 2